



BluePath

DIRECTORY OF BUSINESSES
COMMITTED TO ACCESSIBILITY

www.blue-path.com

ACCESSIBILITY CHECKLIST

— RESTAURANTS —

Developed by

BluePath & DBTAC Northwest

Center for Continuing Education in Rehabilitation

University of Washington

6912 220th Street SW, Suite 105

Mountlake Terrace, WA 98043

Toll Free (800) 949-4232

Fax (425) 774-9303 * TTD (425) 771-7426

BLUEPATH ACCESSIBILITY CHECKLIST

TABLE OF CONTENTS

SECTION	PAGE
Introduction / Disclaimer	
How to Perform an Accessibility Survey	
Priority 1. Parking	
<i>Number of accessible spaces</i>	1
<i>Access aisles and van accessible spaces</i>	2
<i>Curb ramps</i>	3
Priority 2. Accessible Approach and Entrance	
<i>Surfaces and walkways</i>	4
<i>Ramps</i>	5
<i>Door width</i>	7
<i>Door handles and thresholds</i>	8
<i>Protruding objects</i>	9
Priority 3. Access to Goods and Services	
<i>Doors</i>	10
<i>Aisle width, reach and turning space</i>	11
<i>Table placement and height</i>	12
<i>Ramps</i>	13
<i>Elevators</i>	15
<i>Water Fountains</i>	17
<i>ATMs</i>	18
Priority 4. Restrooms	
<i>Entrance, turning space, mirrors and sinks</i>	19
<i>Pipes, floor space, faucets and dispensers</i>	20
<i>Toilets and grab bars</i>	21
<i>Stalls and single-user restrooms</i>	22
Additional Requirements for Restaurants	23
Notes and Sketch Page	A
Contact Information	B

ACCESSIBILITY CHECKLIST DESIGN AND DISCLAIMER

BluePath and the Disability and Business Technical Assistance Center (DBTAC) Northwest are pleased to provide this Accessibility Checklist. This Checklist is designed to be a convenient tool for identifying architectural and communication barriers which prevent full access and which may be encountered by people with disabilities at your business location.

More definitive information may be obtained from your state building code and the Americans with Disabilities Act Accessibility Guidelines for Buildings and Facilities (ADAAG).

The Checklist is designed so that:

'YES' indicates "**ACCESSIBLE**"

'NO' indicates that the item is present but is "**NON-ACCESSIBLE**"

'NAV' (Not AVailable) indicates that the element **does not exist** at the facility

*All dimensions in this Checklist are given in units of inches or feet.
This Checklist will be provided in alternate formats upon request.*

Private Process

Businesses that do not score above a defined level on the assessment will not be placed in danger by a "negative" score. Assessment results will be privately controlled by the business and BluePath only and will not be used by DBTAC, the State or any other government agency for future action of any kind.

The BluePath website will never indicate that a business has not qualified for membership. Only businesses that meet minimum accessibility federal standards, as determined by BluePath, will be processed for official Membership and receive an active profile in the BluePath Directory.

Disclaimers

Please initial your understanding that:

_____ Membership with BluePath does *not* guarantee 100% accessibility and does not specifically limit your business from future legal claims should they arise.

_____ Membership can be revoked if accessibility is not maintained or if consistent, valid complaints are filed against your business.

_____ This Checklist is *not* a substitute for federal accessibility guidelines or the appropriate state and local building codes.

Revised September 2009 by DBTAC Northwest. We encourage duplication and use of this document.

Developed with support of a grant from the National Institute on Disability and Rehabilitation Research (NIDRR) – Project Number H133A070048.

HOW TO PERFORM AN ACCESSIBILITY SURVEY

Planning for the Survey:

If possible, we suggest that a team of two or more individuals carry out the survey. It is very helpful if one person directs the process and takes notes while the other person performs the measurements. It is suggested that people with disabilities be involved in the survey.

Using a Floor Plan: It is often helpful to have a floor plan, or a sketch of a floor plan, for note taking while conducting the survey. Elements on this checklist can be identified on the floor plan.

Tools

- Clipboard to make recording on the checklist easier.
- Flexible steel tape measure.
- Carpenter's level for measuring slope on ramps and inclined walkways.
- Digital fish scale or similar device for measuring door opening force.
- Digital camera to help illustrate barriers and to provide to BluePath for better technical assistance.

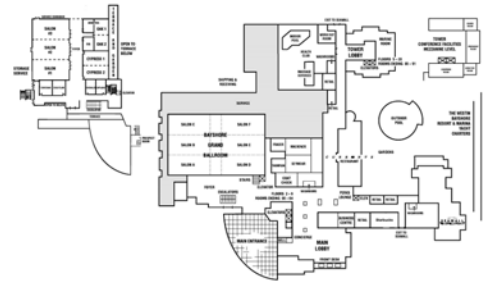

Conducting the Survey:

Measuring clear width (opening) - To measure the clear width (unobstructed open space) at a door, measure the distance between the face of the door and the edge of the door stop. Clear width measurements at other locations (ramps, accessible routes, etc.) are measured in the same manner; measure the width of the unobstructed space for passage.

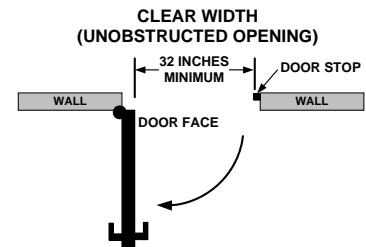

Measuring slope - Slope is measured by taking the ratio of vertical rise to horizontal run. For example, if a ramp 6 inches in vertical height traverses a horizontal distance of 6 feet (72 inches) then the slope is $6 / 72 = 1 / 12 = 0.083$ (8.3%). Typically the maximum allowable slope for a ramp is written as 1:12. To measure the slope, lay one end of a carpenter's level on the uphill side of the ramp, lift the downhill end of the tool to bring it to level (bubble in the middle), and measure the distance between the downhill bottom edge of the level and the ramp surface. See the figure. In this case the slope is 3 inches rise over 36 inches horizontal distance or 1:12.

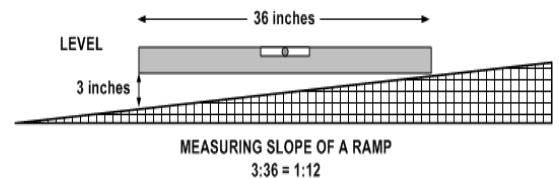
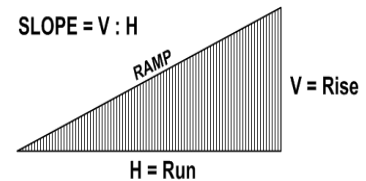

Measuring door opening force - If using a fish scale or similar device, tie one end of the scale to the door handle and observe the maximum force displayed on the scale as you pull the door from a closed position.

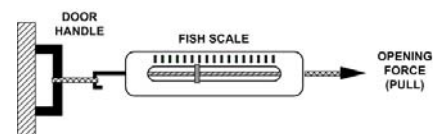

Priority 1: PARKING

People with disabilities should be able to arrive at the site, locate and use accessible parking.

1. Facility Parking

Does your business have parking spaces designated for use by individuals with disabilities?

Note: This does not apply to on-street parking spaces.

*** If your business does not provide a public parking lot, go to Priority 2 on page 4.**

- Yes
 No
 NAV *

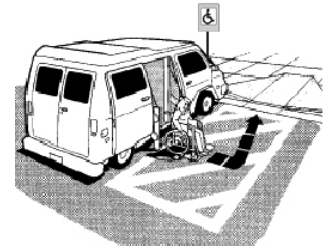

2. Number of Accessible Spaces

Does the parking area have the minimum number of accessible spaces specified in the table below?

Total Parking Spaces	Designated Accessible Parking
1 to 25	1
26 to 50	2
51 to 75	3
76 to 100	4
101 to 150	5
151 to 200	6
201 to 300	7
301 to 400	8
401 to 500	9
501 to 1000	2% of total
1001 and over	20 plus 1 for each 100 over 1000

Note: At least one of every 6 accessible parking spaces must be designated "van accessible." For example, if the facility has only one accessible parking space, then that space must be van accessible. If you have 7 accessible parking spaces then 2 must be van accessible. See Item 5 on the next page.

- Yes
 No *



*** If no, how many accessible parking spaces are available?**

*** What is the total number of parking spaces available for the public?**

3. Space Location

Are the accessible parking spaces located on the shortest possible accessible route to the building entrance?

- Yes
 No

Are the accessible parking spaces located on a level area?

- Yes
 No

Note: Surface slopes should not exceed 1:48 in any direction. (1:50 slope = 1 foot change in vertical elevation over a 48 foot horizontal distance. 1:48 = approximately 2% slope)

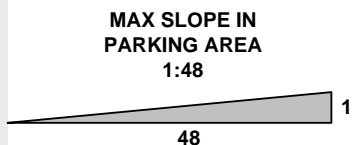

Priority 1: PARKING

4. Parking Identification and Dimensions of Spaces

Are there signs showing the International Symbol of Accessibility posted at a height of at least 5 feet at each accessible parking space?

If No, what are the heights? 1. _____ 2. _____ 3. _____

Are vehicle spaces a minimum of 8 feet wide?

If No, what is the width? _____

Do access aisles adjacent to the vehicle parking spaces have a minimum width of 5 feet?

If No, what is the width? _____

Note: Two accessible parking spaces may share a common access aisle.

Oregon businesses: Are vehicle spaces a minimum of 9 feet wide and access aisles a minimum of 6 feet wide?

If No, what are the widths?

Parking space: _____ Access aisle: _____

Yes

No

Yes

No

Yes

No

Yes

No

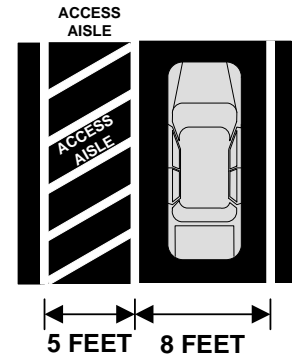

5. Van Accessible Parking Spaces

Is there at least one van accessible space for every eight accessible parking spaces?

If No, how many van accessible spaces? _____

How many total accessible spaces? _____

Are the van accessible parking spaces designated by an additional sign indicating "Van Accessible"?

Do the van accessible parking spaces have a minimum vehicle area width of 8 feet (96 inches) and a minimum accompanying access aisle of at least 8 feet (96 inches)?

OR

Do the van accessible parking spaces have a minimum vehicle area width of 11 feet (132 inches) and an accompanying access aisle of at least 5 feet (60 inches)?

Oregon businesses: Do the van accessible parking spaces have a minimum vehicle area width of 9 feet and an accompanying access aisle of at least 8 feet? (or a total combined parking and access aisle space of 17 feet?)

If No, what are the widths?

Parking space: _____ Access aisle: _____

Yes

No

Yes

No

Yes

No

Yes

No

Yes

No

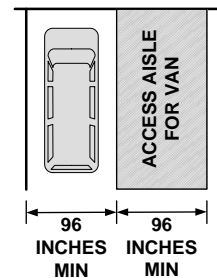

OR

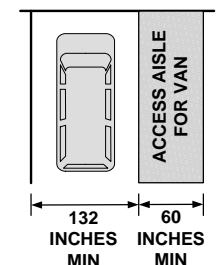

Priority 1: PARKING

6. Passenger Loading Zone

If your business has a passenger loading zone, does it have an unobstructed access aisle at least 5 feet wide and 20 feet long parallel to the vehicle pull-up space?

If No, what is the width? _____ and length? _____

Is the access aisle at the same level as the vehicle pull-up space?

Is the access aisle marked so that people will not park in that space?

- Yes
- No
- NAV
- Yes
- No
- Yes
- No

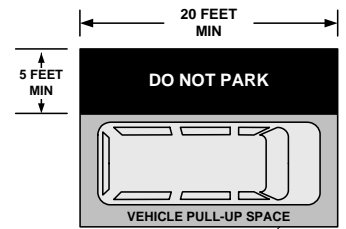

7. Curb Ramps

Are curb ramps provided where accessible routes cross over a curb?

Note: Curb ramps must not project into traffic lanes, parking spaces or access aisles.

Do curb ramps have a maximum slope of 1:12?

If No, what are the slopes? 1. _____ 2. _____ 3. _____

Do curb ramps have a minimum width of 36 inches?

If No, what are the widths? 1. _____ 2. _____ 3. _____

Are the transition areas smooth where curb ramps join sidewalks, streets or gutters?

Are there level landings at the top of the ramps with a minimum width of 36 inches?

If No, what are the widths? 1. _____ 2. _____ 3. _____

Note: Where it is not possible to provide a level landing at the top of a curb ramp, a curb ramp with flared sides that do not exceed a slope of 1:12 is an alternative.

- Yes
- No
- NAV
- Yes
- No
- Yes
- No
- Yes
- No

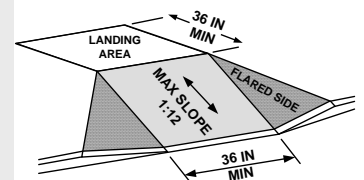

Priority 2: ACCESSIBLE APPROACH AND ENTRANCE (Exterior Routes)

People with disabilities should be able to arrive at the site, approach the building and enter the building as freely as everyone else. At least one accessible route should be safe and accessible for everyone.

1. Ground and Floor Surfaces

Are ground, walk and floor surfaces along accessible routes stable, firm, smooth and slip-resistant?

Note: An “accessible route” may consist of doorways, ramps, curb ramps, elevators, platform lifts and other walking surfaces with a slope no steeper than 1:20.

- Yes
 No



2. Changes in Surface Level

Are all ground and floor surfaces along accessible routes free of abrupt level changes? Surface level changes cannot exceed 1/4 inch in height.

Where vertical elevation changes are between 1/4 and 1/2 inches in height, is the level change beveled with a slope no steeper than 1:2?

Are ramps provided for changes in surface level which exceed 1/2 inch in height? (See ramp requirements on pages 5 and 6).

- Yes
 No
 Yes
 No
 NAV

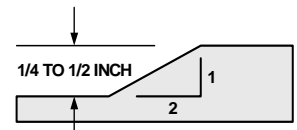
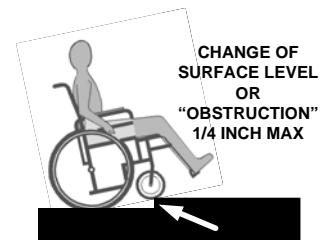

- Yes
 No
 NAV

3. Clear Widths and Slopes for Walkways

Is there at least one accessible route from the accessible parking areas or passenger loading zones to the accessible building entrance?

Do all walkways along accessible routes have a minimum clear, unobstructed width of at least 36 inches?

If No, what is the minimum clear width? _____

Do longer routes have an occasional 5 x 5 feet area located at reasonable intervals not exceeding 200 feet which can be used for turning and passing?

Do all walkways along accessible routes have cross slopes that are 1:48 or less?

Note: When the running slope along the direction of travel on an accessible route is greater than 1:20 (5%) the route is considered a “ramp”. See Items 4-8 on the next two pages).

- Yes
 No
 NAV

- Yes
 No

- Yes
 No

- Yes
 No

MEASURING CLEAR WIDTH OF AN ACCESSIBLE ROUTE IN PRESENCE OF OBSTRUCTIONS WALL

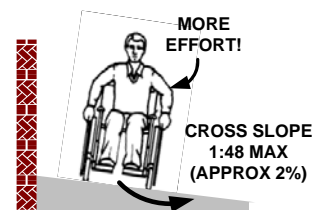
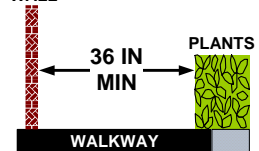

Priority 2: ACCESSIBLE APPROACH AND ENTRANCE (Exterior Routes)

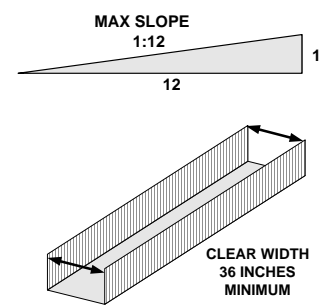
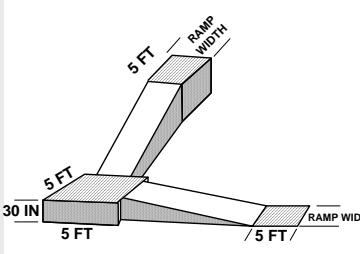
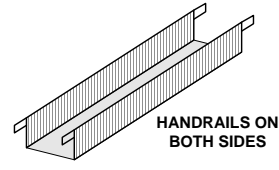
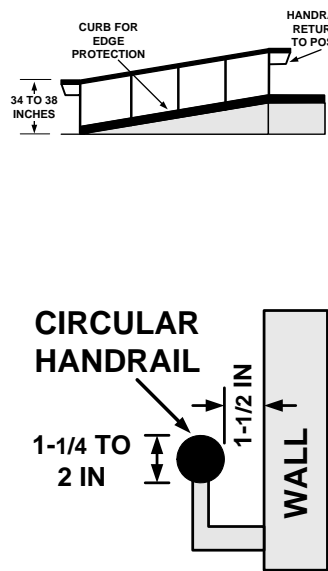
<p>IS THERE A RAMP LOCATED ON THE EXTERIOR OF YOUR BUSINESS SITE?</p>	<p><input type="checkbox"/> Yes <input type="checkbox"/> No</p>	<p>IF NO, SKIP TO #9.</p>
<p>4. Ramp Slope and Clear Width</p> <p>Is the maximum slope of all ramps 1:12 (8.3%)? If No, what is the slope? _____</p> <p>Note: A 1:12 slope is 1 inch of vertical rise to every 12 inches of horizontal distance.</p> <p>Does the ramp have a clear unobstructed width of at least 36 inches? If No, what is the clear width of the ramp? _____</p>	<p><input type="checkbox"/> Yes <input type="checkbox"/> No</p> <p><input type="checkbox"/> Yes <input type="checkbox"/> No</p>	 <p>MAX SLOPE 1:12</p> <p>CLEAR WIDTH 36 INCHES MINIMUM</p>
<p>5. Landings</p> <p>Do ramps have a 5 foot long level landing at the top and bottom of each run? If No, how long is the landing? _____</p> <p>Do ramps have a 5 x 5 foot minimum turning space at level landings where the ramp changes direction? If No, what are the dimensions of the landings? _____ x _____</p> <p>Note: Landings are required where the maximum vertical rise for any length of run for a ramp is 30 inches.</p>	<p><input type="checkbox"/> Yes <input type="checkbox"/> No</p> <p><input type="checkbox"/> Yes <input type="checkbox"/> No <input type="checkbox"/> NAV</p>	 <p>5 FT RAMP WIDTH</p> <p>5 FT</p> <p>30 IN</p> <p>5 FT</p> <p>5 FT RAMP WIDTH</p>
<p>6. Ramp Handrails</p> <p>If the ramp rises more than 6 inches, does it have handrails on both sides?</p>	<p><input type="checkbox"/> Yes <input type="checkbox"/> No <input type="checkbox"/> NAV</p>	 <p>HANDRAILS ON BOTH SIDES</p>
<p>7. Handrail Location</p> <p><i>(Skip if previous question was NAV)</i></p> <p>Are handrails mounted so that their top surface is between 34 and 38 inches above the ramp surface? If No, what is the height of the top of the handrails? _____</p> <p>Do handrails continue to extend horizontally at least 12 inches at the top and bottom landings of the ramp and do these extensions return to the wall, floor or post?</p> <p>If the handrail is mounted on the wall, is the gap between the handrail and the wall exactly 1-1/2 inches? If No, what is the width of the gap? _____</p> <p>If the handrail is circular in shape, is the diameter 1-1/4 inches minimum to 2 inches maximum?</p> <p>If the shape is not circular, does the shape provide an equivalent gripping surface?</p>	<p><input type="checkbox"/> Yes <input type="checkbox"/> No</p> <p><input type="checkbox"/> Yes <input type="checkbox"/> No</p> <p><input type="checkbox"/> Yes <input type="checkbox"/> No <input type="checkbox"/> NAV</p> <p><input type="checkbox"/> Yes <input type="checkbox"/> No</p> <p><input type="checkbox"/> Yes <input type="checkbox"/> No</p>	 <p>CURB FOR EDGE PROTECTION</p> <p>HANDRAIL RETURN TO POST</p> <p>34 TO 38 INCHES</p> <p>CIRCULAR HANDRAIL</p> <p>1-1/4 TO 2 IN</p> <p>1-1/2 IN</p> <p>WALL</p>

Priority 2: ACCESSIBLE APPROACH AND ENTRANCE (Exterior Routes)

8. Protective Edges on Ramps

Do ramps and landings have edge protection?

- Yes
 No

Note: Edge protection can be provided by:

1. By extending the floor surface of a ramp or landing at least 12 inches beyond the railing, or,
2. A curb or barrier that prevents passage of a crutch, a wheel on a wheelchair or other mobility aid from going over the edge of the ramp or landing.

Examples are:

- a. curbs at least 4 inches high,
- b. horizontal rails placed no more than 4 inches from the floor or wall
- c. vertical railing spaced less than 4 inches apart can be used to prevent wheels on wheelchairs and other mobility aids from going off the edge of the ramp.

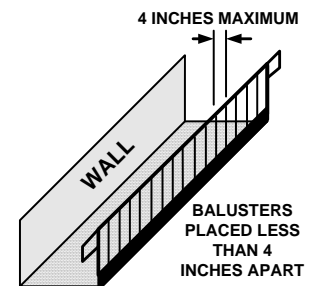
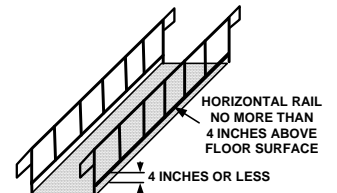
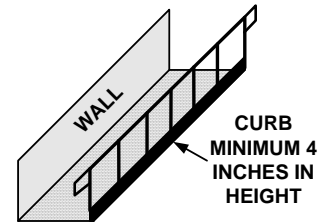

Priority 2: ACCESSIBLE APPROACH AND ENTRANCE (Exterior Routes)

9. Doorway Width and Maneuvering Clearance

Is there a minimum of 60 x 60 inches of level landing space centered at the front of the accessible entrance?

If No, what are the dimensions of the landing? _____

Do accessible entrances have a minimum clear opening (free of protrusions and obstructions) of 32 inches?

If No, what are the widths of the clear openings at entrances?

1. _____ 2. _____ 3. _____

Do the push or pull sides of doors have adequate clearance from the side and front of the doorway to allow customer to reach handle and maneuver around and through the door opening?

If No, what are the side and front (approach) distances? Side: _____ Front: _____

Note: If the person using a wheelchair can approach the door from the front, a minimum side distance of 18 inches and a minimum perpendicular distance of 60 inches will suffice if the door swings toward the customer (shown in top figure).

Note: A minimum of 12 inches side distance and a minimum perpendicular distance of 48 inches is required for a door that swings away from the customer and has a latch and closer (shown in bottom figure).

Note: Automatic or power assisted doors do not typically require these types of maneuvering clearances adjacent to the doors.

Yes

No

Yes

No

Yes

No

NAV

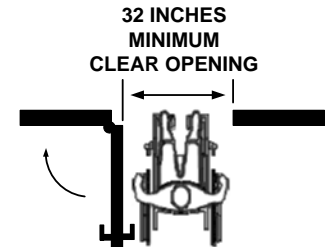

MANEUVERING CLEARANCE AT DOOR
FRONT APPROACH TO PULL FACE OF DOOR

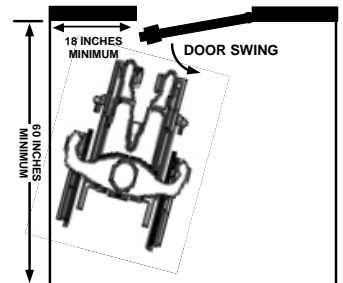

MANEUVERING CLEARANCE AT DOOR
FRONT APPROACH TO PUSH FACE OF DOOR
WITH A CLOSER AND LATCH

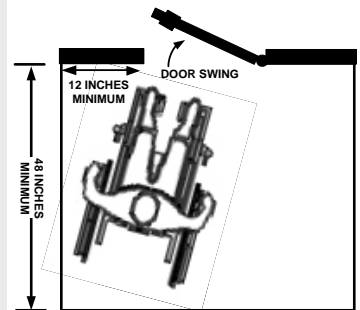

10. Door Opening Force

Is the force required to open accessible exterior entrances no more than 10 pounds?

If No, what is the opening force? _____

Yes

No

NAV

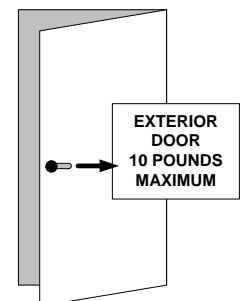

Priority 2: ACCESSIBLE APPROACH AND ENTRANCE (Exterior Routes)

11. Door Hardware

Are handles, pulls, latches, locks, and other operating devices on accessible doors easily grasped with one hand, and require no tight grasping, pinching, or twisting of the wrist to operate?

Note: Lever and loop handles serve this purpose well.

Are door handles mounted no higher than 48 inches and no lower than 34 inches from the floor surface?

- Yes
 No
 NAV

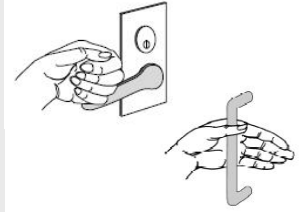

- Yes
 No

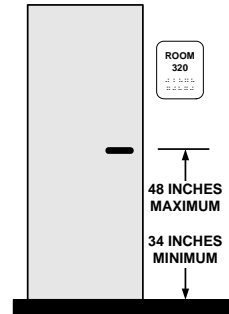

12. Doors in Series

If two doors in a series swing in the same direction (see top figure), is the distance between the walls (door surfaces when closed) at least 48 inches plus the width of the in-swinging door?
 If No, what is this distance? _____

If two doors in series swing in opposite directions (see bottom figure) is the distance between the walls (door surfaces when closed) at least 48 inches?
 If No, what is this distance? _____

- Yes
 No
 NAV

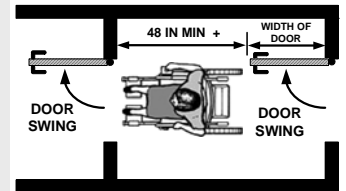

- Yes
 No
 NAV

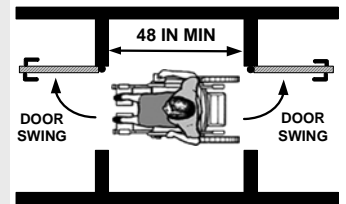

13. Thresholds

Are the heights of all thresholds 1/2 inch or less?
 If No, what are the heights? 1. _____ 2. _____ 3. _____

Note: Threshold edges between 1/4 and 1/2 inches in height should be beveled at a slope no greater than 1:2.

Note: Existing thresholds between 1/2 and 3/4 inches in height are allowable if they are beveled at a maximum slope of 1:2 on both sides. See bottom figure.

- Yes
 No
 NAV

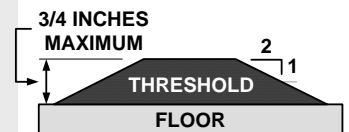
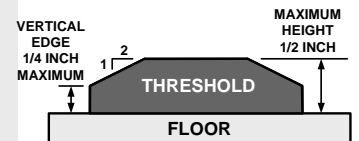

Priority 2: ACCESSIBLE APPROACH AND ENTRANCE (Exterior Routes)

14. Protruding Objects

Do protruding and hanging objects with a leading edge more than 27 inches above the floor, protrude no more than 4 inches into the path of travel?

If No, how far do the objects protrude? _____

Note: Examples include telephones, water fountains, signs, planters, lamps, etc.

Do walks, halls, corridors, passageways, aisles or other circulation spaces have a minimum head clearance of 80 inches?

If No, how far is the overhead object from floor level? _____

- Yes
- No

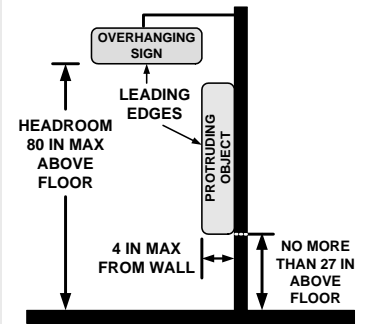

- Yes
- No

15. Suspended Stairs

Are all suspended stairs or other overhead obstructions provide sufficient warning devices, for example, railings, planters, etc., to alert people who are visually impaired?

- Yes
- No
- NAV

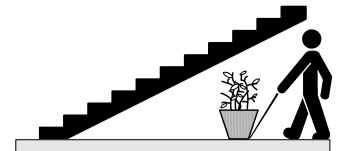

Priority 3: ACCESS TO GOODS AND SERVICES (Interior Routes and Spaces)

Ideally, the layout of the building should allow people with disabilities to obtain goods or services without special assistance. Where it is not possible to provide full accessibility, assistance or alternative services should be available upon request.

1. Doors in Public Spaces

Do the interior doors in public spaces have at least a 32-inch clear, unobstructed opening?

If No, what are the opening widths of the doors?

1. _____ 2. _____ 3. _____

Note: With double doors, at least one door must have a minimum clear opening of 32 inches.

- Yes
 No
 NAV

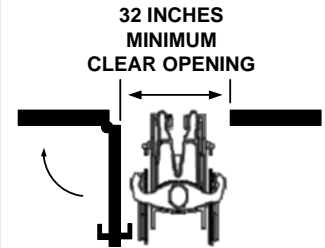

2. Maneuvering Clearance

Do the pull and push sides of doors have adequate maneuvering clearances in front of and to the sides of doorways so that a person using a wheelchair can position themselves to open the door?
 (See Priority 2, Item 12 on page 8 for more information)

If No, what are the side and front (approach) distances? Side: _____ Front: _____

- Yes
 No
 NAV

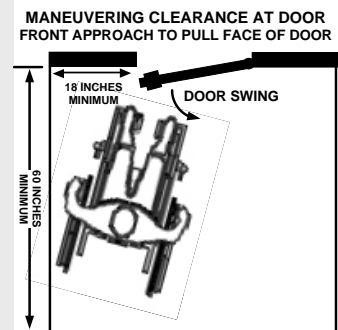

3. Signs for Permanent Rooms and Spaces

Are signs designating permanent rooms and spaces, such as restrooms or conference rooms, designed to have good contrast between characters and background, adequate character size for viewing distance, raised (tactile) characters and Braille?

Are signs mounted so the tactile characters on the sign are between 48 and 60 inches from the floor surface?

If No, what is the height? _____

- Yes
 No
 NAV

 Yes
 No

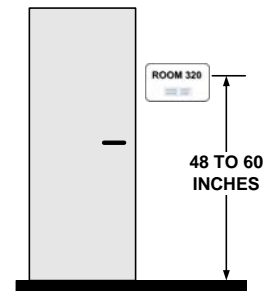

4. Door Opening Force

Can interior doors be opened with 5 lb or less force?

If No, what is the force required to open the doors?

1. _____ 2. _____ 3. _____

- Yes
 No
 NAV

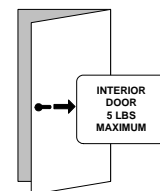

5. Door Handle Height

Are door handles mounted no higher than 48 inches and no lower than 34 inches from the floor surface?

If No, what is the height? 1. _____ 2. _____ 3. _____

- Yes
 No
 NAV

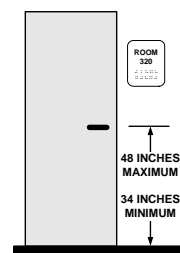

Priority 3: ACCESS TO GOODS AND SERVICES (Interior Routes and Spaces)

6. Door Hardware

Do all latch doors along an accessible route have a handle that does not require tight grasping, pinching, or twisting to operate?

If there is no latch, do the doors have pulls, loops or push plates?

- Yes
 No
 NAV
 Yes
 No
 NAV

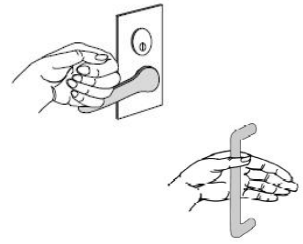

7. Thresholds

Are the heights of all thresholds 1/2 inch or less?

If No, what are the heights? 1. _____ 2. _____ 3. _____

(See Priority 2, Item 13 on page 8 for more details).

- Yes
 No
 NAV

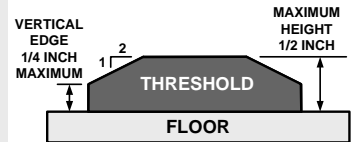

8. Aisle Width and Reach to Products

Do all aisles and pathways to goods and services have a minimum clear, unobstructed passage width of 36 inches?

If No, what are these minimum passage widths?

1. _____ 2. _____ 3. _____

If products or goods are available, are they within reach?

Note: For a forward reach, the maximum height is 48 inches and the minimum low distance from the floor is 15 inches. For a side reach, the maximum height is 54 inches and the minimum height should be 9 inches.

If No, what are the maximum and minimum heights?

Forward (Max) 1. _____ 2. _____ 3. _____ (Min) 1. _____ 2. _____ 3. _____

Side (Max) 1. _____ 2. _____ 3. _____ (Min) 1. _____ 2. _____ 3. _____

- Yes
 No
 Yes
 No
 NAV

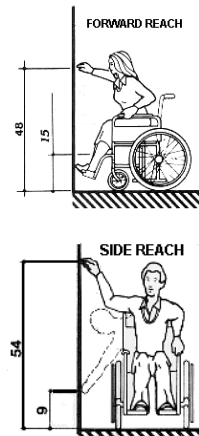

9. Turning Space

Is there adequate turning space for a wheelchair or other mobility device?

Note: A turning space may have:

1. A minimum diameter of 60 inches (top figure), or,
2. T-shaped space where the width is not less than 36 inches (bottom figure).

If No, what are the turning diameters or widths of the spaces available?

1. _____ 2. _____ 3. _____

- Yes
 No

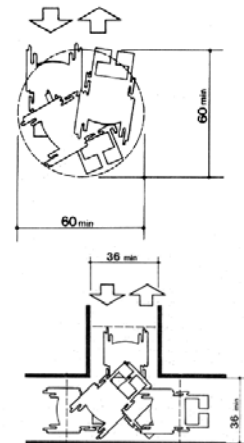

10. Carpeting

Is carpeting low-pile, tightly woven, and securely attached along edges?

Note: Carpet pile thickness should be less than 1/2 inch.

- Yes
 No
 NAV

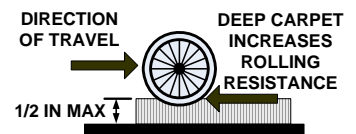

Priority 3: ACCESS TO GOODS AND SERVICES (Interior Routes and Spaces)

IS THIS BUSINESS A RESTAURANT?

Yes **Go to Item 13**

If YES, skip items 11-12 as these items will be covered later in the checklist for dining areas, pages 23-24.

No **Go to Item 11**

11. Table Placement and Seating Distribution

If tables or work surfaces are available, is there a 36 inch aisle clearance and a 30 inch wide space at the tables or work surfaces for wheelchair access?

If No, what are the widths of the aisle clearances?

1. _____ 2. _____ 3. _____

- Yes
 No
 NAV

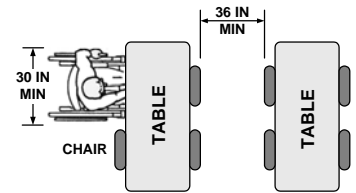

Are seating spaces for wheelchairs distributed throughout?

Note: People should be able to choose the locations and types of tables, seating and other furnishings.

Do seating spaces at tables allow for a forward approach and provide a clear floor space of 30 by 48 inches?

- Yes
 No
 Yes
 No

MINIMUM CLEAR FLOOR SPACE SEATING AND TABLES

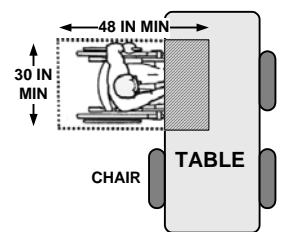

12. Table Height and Legroom

Does the space under MOST tables have legroom (clear opening for knee space) of at least 27 inches in height, 30 inches in width, and 17 inches in depth?

If No, what are the dimensions available for leg clearance?

H: _____ W: _____ D: _____

Is the top surface of the table 28 inches minimum to 34 inches in maximum height?

If No, what is the table top height? _____

- Yes
 No
 Yes
 No

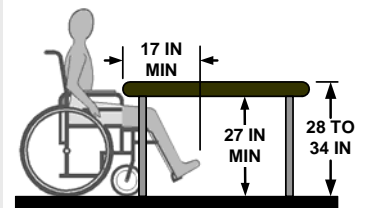

13. Protruding Objects on the Interior of Your Facility

Do protruding and hanging objects with a leading edge more than 27 inches above the floor, protrude no more than 4 inches into the path of travel?

If No, how far do the objects protrude? _____

Do walks, halls, corridors, passageways, aisles or other circulation spaces have a minimum head clearance of 80 inches?

If No, how far is the overhead object from floor level? _____

- Yes
 No
 NAV
 Yes
 No

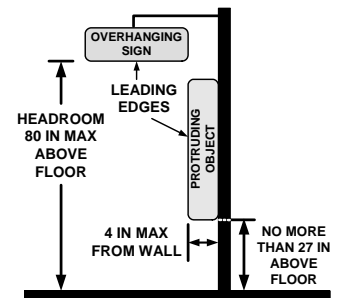

Priority 3: ACCESS TO GOODS AND SERVICES (Interior Routes and Spaces)

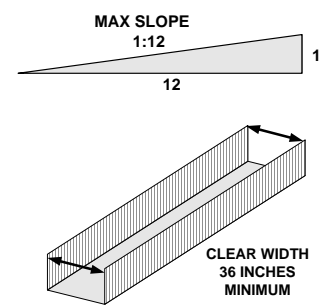
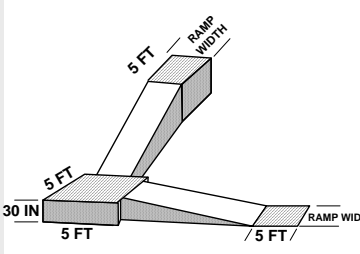
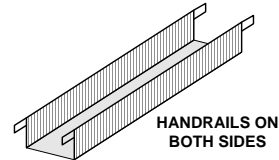
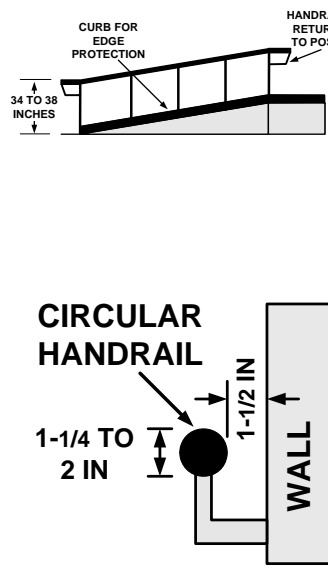
<p>IS THERE A RAMP LOCATED ON THE INTERIOR OF YOUR BUSINESS SITE?</p>	<p><input type="checkbox"/> Yes <input type="checkbox"/> No</p>	<p>IF NO, SKIP TO #9.</p>
<p>14. Ramp Slope and Clear Width</p> <p>Is the maximum slope of all ramps 1:12 (8.3%)? If No, what is the slope? _____</p> <p>Note: A 1:12 slope is 1 inch of vertical rise to every 12 inches of horizontal distance.</p> <p>Does the ramp have a clear unobstructed width of at least 36 inches? If No, what is the clear width of the ramp? _____</p>	<p><input type="checkbox"/> Yes <input type="checkbox"/> No</p> <p><input type="checkbox"/> Yes <input type="checkbox"/> No</p>	 <p>MAX SLOPE 1:12</p> <p>CLEAR WIDTH 36 INCHES MINIMUM</p>
<p>15. Landings</p> <p>Do ramps have a 5 foot long level landing at the top and bottom of each run? If No, how long is the landing? _____</p> <p>Do ramps have a 60 x 60 inch minimum turning space at level landings where the ramp changes direction? If No, what are the dimensions of the landings? _____ x _____</p> <p>Note: Landings are required where the maximum vertical rise for any length of run for a ramp is 30 inches.</p>	<p><input type="checkbox"/> Yes <input type="checkbox"/> No</p> <p><input type="checkbox"/> Yes <input type="checkbox"/> No <input type="checkbox"/> NAV</p>	 <p>5 FT RAMP WIDTH</p> <p>5 FT</p> <p>30 IN</p> <p>5 FT</p> <p>5 FT RAMP WIDTH</p>
<p>16. Ramp Handrails</p> <p>If the ramp rises more than 6 inches, does it have handrails on both sides?</p>	<p><input type="checkbox"/> Yes <input type="checkbox"/> No <input type="checkbox"/> NAV</p>	 <p>HANDRAILS ON BOTH SIDES</p>
<p>17. Handrail Location</p> <p><i>(Skip if previous question was NAV)</i></p> <p>Are handrails mounted so that their top surface is between 34 and 38 inches above the ramp surface? If No, what is the height of the top of the handrails? _____</p> <p>Do handrails continue to extend horizontally at least 12 inches at the top and bottom landings of the ramp and do these extensions return to the wall, floor or post?</p> <p>If the handrail is mounted on the wall, is the gap between the handrail and the wall exactly 1-1/2 inches? If No, what is the width of the gap? _____</p> <p>If the handrail is circular in shape, is the diameter 1-1/4 inches minimum to 2 inches maximum?</p> <p>If the shape is not circular, does the shape provide an equivalent gripping surface?</p>	<p><input type="checkbox"/> Yes <input type="checkbox"/> No</p> <p><input type="checkbox"/> Yes <input type="checkbox"/> No</p> <p><input type="checkbox"/> Yes <input type="checkbox"/> No</p> <p><input type="checkbox"/> Yes <input type="checkbox"/> No</p> <p><input type="checkbox"/> Yes <input type="checkbox"/> No</p>	 <p>CURB FOR EDGE PROTECTION</p> <p>HANDRAIL RETURN TO POST</p> <p>34 TO 38 INCHES</p> <p>CIRCULAR HANDRAIL</p> <p>1-1/2 IN</p> <p>1-1/4 TO 2 IN</p> <p>WALL</p>

Priority 3: ACCESS TO GOODS AND SERVICES (Interior Routes and Spaces)

18. Protective Edges on Ramps

Do ramps and landings have edge protection?

- Yes
 No

Note: Edge protection can be provided by:

1. By extending the floor surface of a ramp or landing at least 12 inches beyond the railing, or,
2. A curb or barrier that prevents passage of a crutch, a wheel on a wheelchair or other mobility aid from going over the edge of the ramp or landing.

Examples are:

- a. curbs at least 4 inches high,
- b. horizontal rails placed no more than 4 inches from the floor or wall
- c. vertical railing spaced less than 4 inches apart can be used to prevent wheels on wheelchairs and other mobility aids from going off the edge of the ramp.

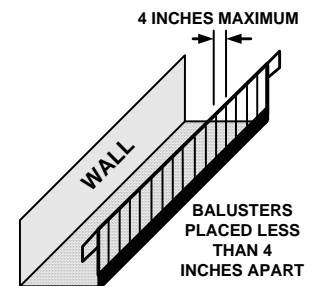
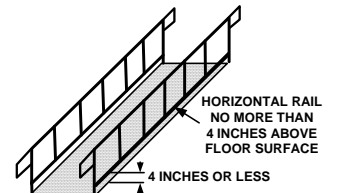
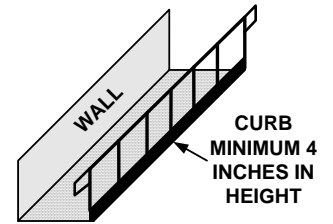

Priority 3: ACCESS TO GOODS AND SERVICES (Interior Routes and Spaces)

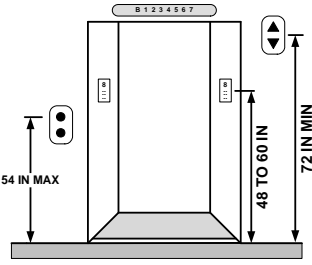
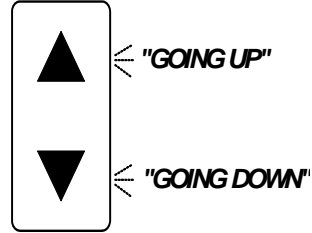
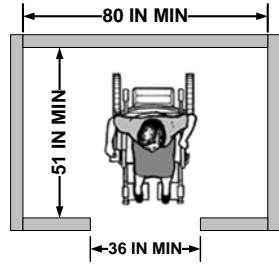
<p>DOES THE FACILITY HAVE A PASSENGER ELEVATOR?</p>	<p><input type="checkbox"/> Yes <input type="checkbox"/> No</p>	<p>IF NO... SKIP TO #27.</p>
<p>19. Hall Call Buttons and Entrance Labels</p> <p>Are call buttons in lobbies and halls mounted no higher than 54 inches when measured to centerline of highest operable part above the floor? If No, what is the height? _____</p> <p>Are there raised (tactile) characters and Braille to indicate floor destinations on both elevator jamba 60 inches above the floor surface?</p>	<p><input type="checkbox"/> Yes <input type="checkbox"/> No</p> <p><input type="checkbox"/> Yes <input type="checkbox"/> No</p>	
<p>20. Signal Identification</p> <p>Are there both visual and audible signals to identify when an elevator car arrives and its direction of travel?</p> <p>Visual: <input type="checkbox"/> Yes <input type="checkbox"/> No</p> <p>Audible: <input type="checkbox"/> Yes <input type="checkbox"/> No</p>	<p><input type="checkbox"/> Yes <input type="checkbox"/> No</p> <p><input type="checkbox"/> Yes <input type="checkbox"/> No</p>	
<p>21. Elevator Car Dimensions</p> <p>Do elevators have minimum inside dimensions of 51 inches in depth by 80 inches in width and a clear door opening of 42 inches? If No, what is the depth, width, and clear door opening? D: _____ W: _____ O: _____</p>	<p><input type="checkbox"/> Yes <input type="checkbox"/> No</p>	

Priority 3: ACCESS TO GOODS AND SERVICES (Interior Routes and Spaces)

22. Leveling

Does the elevator stop within 1/2 inch of the outside floor surface on each level?

- Yes
 No

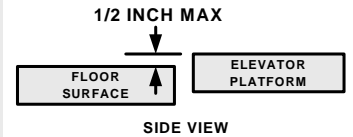

23. Gap Between Elevator and Floor

Is the open space between the outside floor surface and the elevator platform no greater than 1-1/4 inches?

- Yes
 No

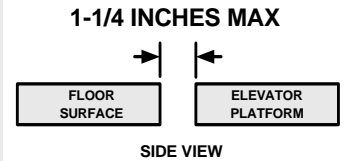

24. Protective Re-Opening Device

Are the elevators equipped with door protection and reopening devices that automatically opens the door when it becomes obstructed or contacted by an object or person?

- Yes
 No

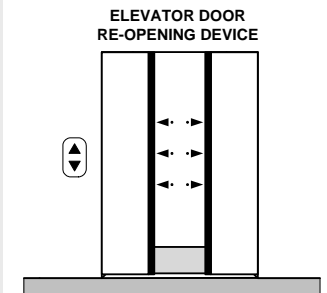

25. Car Controls and Position Indicators

Are car controls, call buttons, and alarm buttons at least 3/4 inch in diameter with Braille and raised lettering?

- Yes
 No

Are all controls or buttons on the inside elevator control panel mounted no higher than 48 inches above the floor?

If No, what is the distance from the elevator floor to the highest control? _____

- Yes
 No

Are emergency control buttons mounted at 35 inches minimum height above the floor?

- Yes
 No

Are visual and audible prompts provided in the interior of the car to indicate car position? (floor/level)

- Visual: Yes
 No

- Audible: Yes
 No

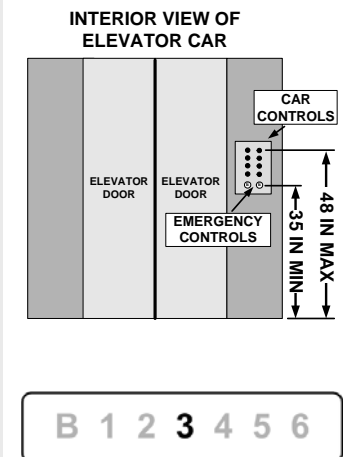

26. Emergency Communications

Are emergency two-way communication systems provided between elevator interior and a point outside?

- Yes
 No

If emergency communications are provided, are they identified by raised lettering and a symbol and is the highest operable part located no higher than 48 inches?

- Yes
 No



Priority 3: ACCESS TO GOODS AND SERVICES (Interior Routes and Spaces)

IS THERE A WATER FOUNTAIN PROVIDED AT YOUR BUSINESS SITE?

- Yes **IF NO...**
 No **SKIP TO #30.**

27. Height

Is there at least one wheelchair accessible water fountain available that is mounted to provide a minimum clearance of 27 inches and a maximum depth of 19 inches so that it can be approached and used by a person in a wheelchair?

- Yes
 No



Is the maximum height of the spout 36 inches or less from the floor?

- Yes
 No

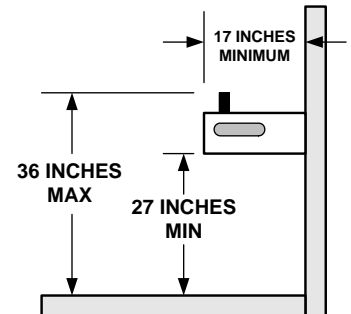

If the water fountain is installed in an alcove more than 8 inches deep, Is the width of the alcove at least 30 inches?

- Yes
 No
 NAV

28. Access to Water Fountain

If the wheelchair accessible water fountain is a wall- or post-mounted model, is there a minimum 30 x 48 inch clear floor space to allow a person to approach and drink while facing forward?

If No, what is the clear floor space? _____ x _____

- Yes
 No
 NAV

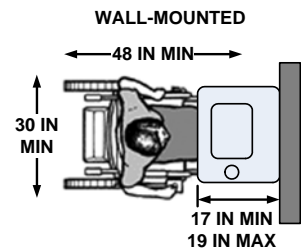

If free-standing or built-in water fountains do not have a clear, open space under them, is there clear floor space of 30 x 48 inches for parallel approach plus space for maneuvering?

If No, what is the clear floor space? _____ x _____

- Yes
 No
 NAV

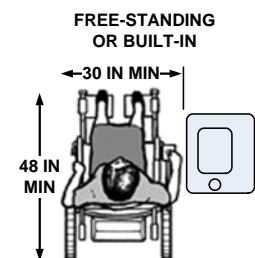

Is the spout of the drinking fountain located in the front of the unit with a water flow trajectory that is parallel or nearly parallel to the front of the unit?

- Yes
 No

29. Hand Controls

Are the controls on the water fountain located on the front of the unit or no more than 6 inches from the front of the unit and can the controls be operated with one hand, not requiring tight grasping, pinching, or twisting, and can the controls be operated with 5 pounds of force or less?

- Yes
 No



Priority 3: ACCESS TO GOODS AND SERVICES (Interior Routes and Spaces)

30. Automated Teller Machines (ATM)

Is there sufficient clear floor space (30 x 48 inches) adjacent to the ATM to allow for forward or parallel approach by a wheelchair?

Is the maximum height of all operable controls or buttons 48 inches for a front approach or 54 inches for a parallel approach by a wheelchair?

Are instructions and information for use of the ATM accessible to persons with visual impairments?

Note: Function keys should contrast visually from background and machine may be “speech-enabled” and have Braille instructions for speech mode, etc.

NAV

Yes

No

Yes

No

Yes

No



Priority 4: PUBLIC RESTROOMS

If your facility has public restrooms, at least one for each gender or one unisex (single-user) must be accessible.

Does your facility offer restrooms to the public? Yes No

If no, skip all of Priority 4.

Note: M = Men's W = Women's

1. Restroom Identification

Are the accessible restrooms clearly marked with a sign of the International Symbol of Accessibility and mounted so the tactile characters are between 48 and 60 inches from the floor?

If No, what are the heights? M: _____ W: _____

Do the signs identifying the accessible restrooms have raised (tactile) and Braille characters?

Yes

No

Yes

No

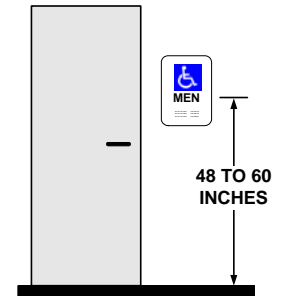

2. Restroom Entrances

Do accessible restroom entrances have a clear opening of 32 inches and maneuvering clearance adjacent to both sides of the doors which conforms to Priority 2, Item 9 on page 8?

If No, what are the clear openings? M: _____ W: _____

Yes

No

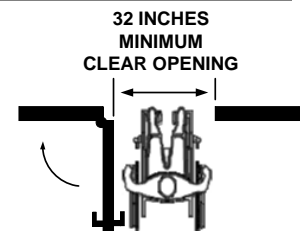

3. Turning Space

Is there adequate turning space for a wheelchair or other mobility device inside the restroom?

Note: A turning space may have a minimum diameter of 60 inches or a T-shaped space where the width is not less than 36 inches. See Priority 3, Item 9 on page 12.

If No, what are the turning diameters or widths of the _____ spaces available?

M: _____ W: _____

Yes

No

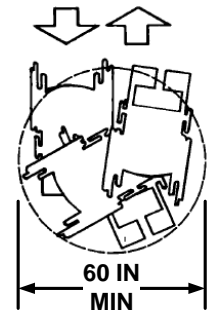

4. Sink Heights

Is there at least one sink mounted so that the counter or rim surface is no higher than 34 inches above the floor?

Is the knee clearance space at least 29 inches from the bottom of sink aprons to the floor?

Are drain pipes mounted so that there is at least 9 inches of toe clearance from the floor surface?

Yes

No

Yes

No

Yes

No

NAV

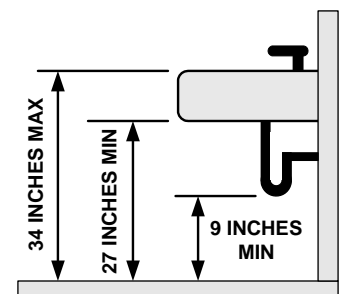

If No to any of the above, what are the measurements?

top surface height: _____

bottom surface height: _____

Toe clearance below pipe: _____

There is no knee or toe clearance under sinks.

Priority 4: PUBLIC RESTROOMS

5. Protective Pipe Covering

Is insulation or other protective covering used on exposed hot water and drain pipes under the sinks?

- Yes
 No
 NAV

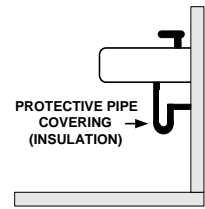

6. Sink Clear Floor Space

Is there clear floor space (30 x 48 inches) provided in front of sinks to allow for forward approach?

Note: A maximum of 19 inches out of the required 48 inches of clear floor space can be under the sink.

If No, what are the dimensions of the clear space?

M: _____ W: _____

Is the total depth of knee and toe clearance beneath sinks at least 17 inches?

- Yes
 No

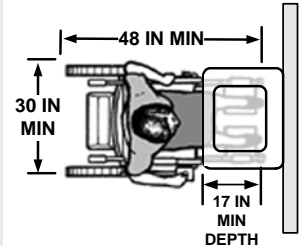

- Yes
 No

Note: 17 inches allows for a combination of 11 inches of knee space (to the drain pipe for example) and an additional 6 inches for toe space (below pipe) to the wall.

If No, what is the knee and toe clearance?

M: (knee) _____ (toe) _____ W: (knee) _____ (toe) _____

7. Faucet Controls

At accessible sinks, are the faucets controlled by a hand lever, push button, or electronic control that is easily operated by one hand, not requiring tight grasping, pinching, or twisting and requiring a maximum of 5 pounds of force or less for operation?

Are faucet handles located at 17 inches or closer to the front edge of the sink?

- Yes
 No
 NAV

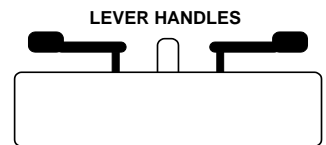

- Yes
 No

8. Restroom Mirror

Does each accessible restroom have at least one mirror mounted 40 inches from the floor to the bottom edge of the reflective surface?

If No, what are the heights? M: _____ W: _____

- Yes
 No
 NAV

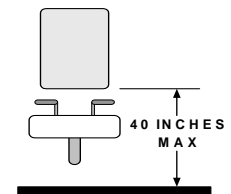

9. Dispensers in Restroom

Are the soap/towel dispensers and other accessories mounted so that there is no more than 48 inches to the highest control or operable part?

Note: Dispensers that can be reached from a side approach may be mounted so that there is no more than 54 inches to the highest operable control of the dispenser.

- Yes
 No

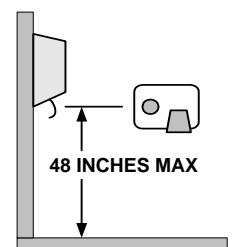

Priority 4: PUBLIC RESTROOMS

Toilets in accessible stalls and accessible single-user (unisex) restrooms must meet the following requirements (Items 10 through 13).

10. Toilet Seat Height and Distance from Wall

Is the top of the accessible toilet seat 17 to 19 inches from the surface of the floor?

If No, how high is the toilet seat? M: _____ W: _____

Is the center of the toilet 16 inches minimum to 18 inches maximum from the side wall or partition?

If No, how far are the centerlines from the wall or partition?

M: _____ W: _____

Yes

No

Yes

No

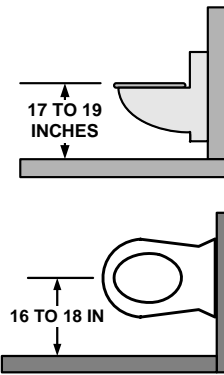

11. Grab Bars

Are two grab bars provided that include a 42 inch long bar on the side wall and a 36 inch long bar on the back wall (behind the toilet) and mounted at 33 to 36 inches above the floor?

If No, what are the lengths and mounting heights of the grab bars?

Side wall grab bar lengths M: _____ W: _____

Back wall grab bar lengths M: _____ W: _____

Mounting heights of grab bars M: _____ W: _____

Is the diameter of each grab bar 1-1/4 to 2 inches?

If No, what are the diameters? M: _____ W: _____

Is the space between the wall and each grab bar 1-1/2 inches?

If No, what is the space between the walls and grab bars? M: _____ W: _____

Is each grab bar mounted securely to the wall or partition?

Yes

No

Yes

No

Yes

No

Yes

No

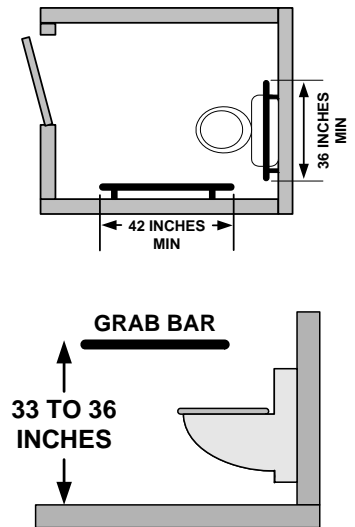

12. Flush Controls

Are the flush controls mounted no higher than 48 inches above the floor on the open side of the toilet area?

If No, at what height are they mounted?

M: _____ W: _____

Are flush controls operable with one hand, not requiring tight grasping, pinching, or twisting of the wrist or more than 5 lbs of force?

Yes

No

Yes

No

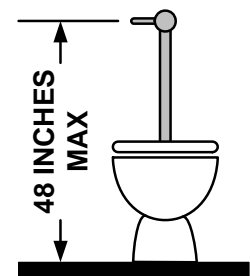

13. Dispensers in Toilet Stall

Are seat cover dispensers located within easy reach?

Do toilet paper dispensers provide a continuous flow of paper and are they installed at least 15 inches above the floor?

...and at a distance between 7 and 9 inches from the front edge of the toilet to the center of the dispenser?

Yes

No

Yes

No

Yes

No

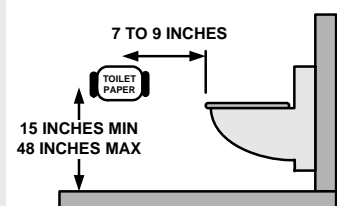

Priority 4: PUBLIC RESTROOMS

If you have single-user restrooms without a stall, skip to Item 16 for single-user restrooms.

If you have multiple- or single-user restrooms with stalls at least one must be accessible and meet the requirements in Items 14 and 15 .

14. Stall Door

Do the accessible stalls have a clear opening of 32 inches and sufficient maneuvering clearance in front of and to the side of the latch? (See Priority 2, Item 9 on page 8)

If No, what is the width? M: _____ W: _____

Does stall door swing outward?

Note: For wheelchair accessible toilet stalls at the end of a row, the door may swing inward as long as sufficient maneuvering space is provided inside the stall.

Yes

No

Yes

No

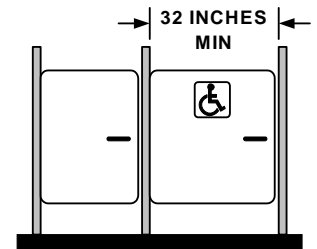

15. Wheelchair Accessible Stall Size

If toilet stalls are provided, at least one should be wheelchair accessible. Do the wheelchair accessible stalls provide a minimum depth of 56 inches (wall-mounted toilets) or 59 inches (floor mounted toilets) and a width of 60 inches?

If No, what is the depth? M: _____ W: _____

width? M: _____ W: _____

Yes

No

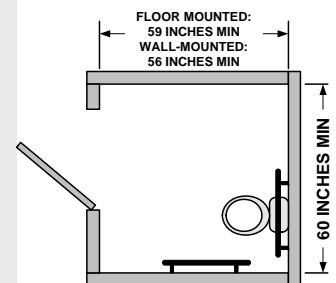

16. Single-Occupant (Unisex) Toilet Rooms

There should be no obstructions within the space around the toilet, nor should a door swing into this space.

Is the floor space around the toilet:

60 inches minimum measured from the side wall?

If No, what are the side wall distances? M: _____ W: _____

56 inches minimum measured from the back wall?

If No, what are the rear wall distances? M: _____ W: _____

NAV

Yes

No

Yes

No

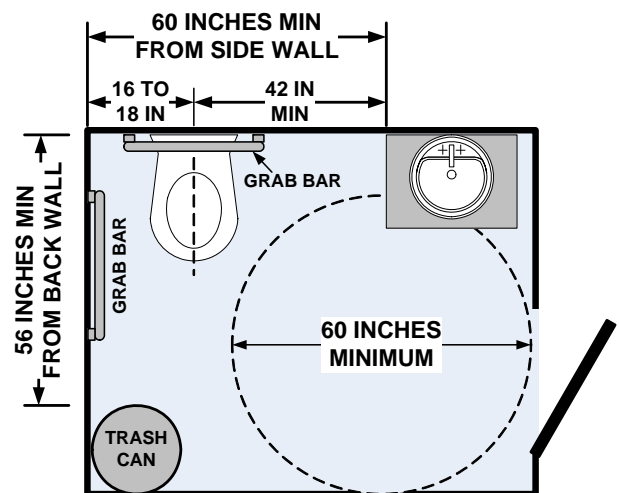

**SINGLE-OCCUPANT
TOILET ROOM**

RESTAURANTS

1. Seating, Tables and Food Service Counters

Do the routes around all table and seating areas, including waiting lines, have a clear opening of at least 36 inches?
If No, what are the widths of the clear openings?

_____, _____, _____, _____, _____, _____

Can chairs be spaced to provide a 30 inch wide space at the table for wheelchair access?

Do seating spaces at tables allow for a forward approach and provide a clear floor space of 30 x 48 inches?

If No, what are the dimensions of the spaces provided?

____ x ____ / ____ x ____ / ____ x ____ / ____ x ____

Is the top surface of the dining table 28 inches minimum to 34 inches maximum height from floor surface?
If No, what are the table top heights? _____

Does the space under tables have leg and toe room that provides at least 27 inches in height, 30 inches in width, and 17 inches in depth?

If No, what are the dimensions available for leg clearance?
H: _____ W: _____ D: _____

Are wheelchair seating spaces distributed throughout?

Note: This provides customer choice in seating location and type, reservation time or other services offered.

- Yes
- No

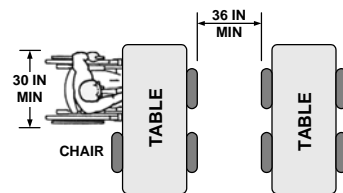

- Yes
- No

MINIMUM CLEAR FLOOR SPACE SEATING AND TABLES

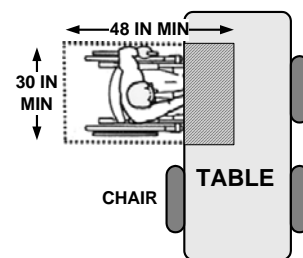

- Yes
- No

- Yes
- No

- Yes
- No

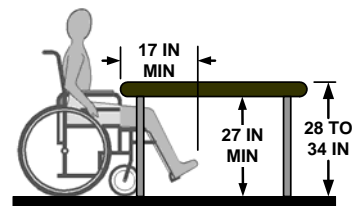

- Yes
- No

2. Cafeteria / Buffet Lines

Are food service lines accessible with an adjacent aisle at least 36 inches wide with adequate turning space at corners?
If No, what is the aisle width? _____

Is the tray slide surface mounted at a maximum height of 34 inches above the floor?
If No, what is the height? _____

Are food selections within 24 inches side reach (measured from the front edge of the tray slide)?

- Yes
- No
- NAV

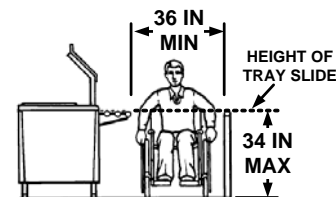

- Yes
- No

- Yes
- No

RESTAURANTS

3. Dining Counters and Bars

Where food or drink is served at counters or bars exceeding 34 inches in height, is there a portion structurally integrated into the main counter that is a minimum of 60 inches long that provides a maximum height of 34 inches?

If no, what is the lowered height and width, if any?

H: _____ W: _____

- Yes
- No
- NAV

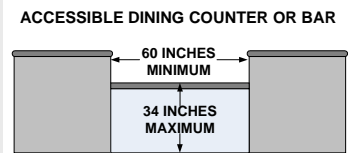

4. Utensil and Condiment Areas

Are 50% or more of self-service shelves and dispensing devices designed so that a person in a wheelchair can approach the shelf or device and reach the products or operable parts?

Note: This may require a forward or parallel approach and clear floor space (minimum 30 x 48 inches) and adequate reach range (see Item #8 in Priority 3, page 11).

- Yes
- No
- NAV

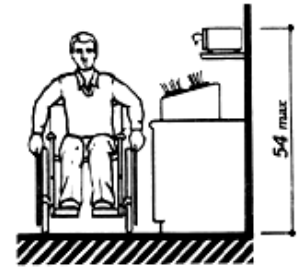

5. Fixed Tables

If only fixed (built-in) tables and seating are provided, are at least 5%, but not less than one fixed table, accessible?

- Yes
- No
- NAV

Please use this space to write us notes or provide us with a sketch:

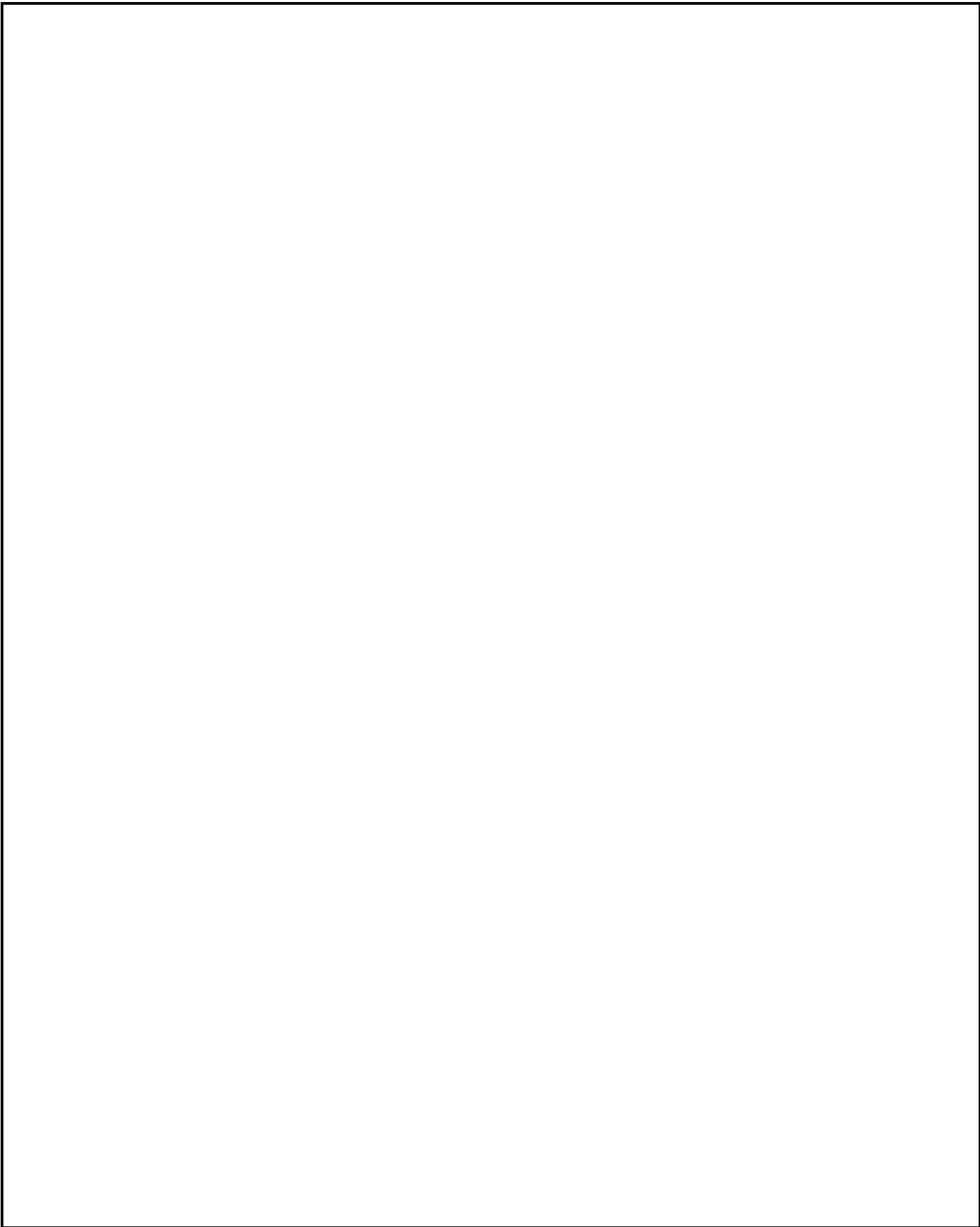
A large, empty rectangular box with a black border, intended for the user to write notes or provide a sketch.

CONTACT INFORMATION

Name of Business: _____

Address: _____

City: _____ State: _____ Zip: _____

Do you know what year this building was constructed? _____

Name of persons performing survey:

_____ Signature: _____

_____ Signature: _____

Contact information (phone or email): _____

Date of completion: _____

How long did it take you to perform this survey? _____

Do you have suggestions about the survey design or the instructions?

Do you have comments about the self-assessment process?

Mail this checklist to: BluePath
6912 220th St. SW #105
Mountlake Terrace, WA 98043

For BluePath Use Only:

Accepted for Membership?

Reviewed by:

Date:

Yes

Delayed